

500-BARREL STEEL TEMPORARY LIQUID STORAGE TANKS



*Easy to clean,
smooth-wall interior*



ADLER 500-BARREL (21,000 GALLON) STEEL TEMPORARY LIQUID STORAGE TANKS FEATURE THE MOST RECENT ADVANCES TO ENHANCE SAFETY AND USABILITY. FROM THE INNOVATIVE SAFETY STAIRWAY AND GRIP STRUT STEPS TO HIGH-VISIBILITY PAINT ON RAILS AND STAIR STEPS, EVERY PART OF AN ADLER TANK IS DESIGNED TO SAFEGUARD WORKERS AND ENHANCE EFFICIENCY.

Adler tanks are ruggedly constructed and may be specified with bare steel or epoxy-coated interiors. Conveniently located manways, multiple valved ports and available heating coils make Adler tanks versatile and efficient on the job site. They are also designed for easy cleaning, making them more cost-effective for you.

Mechanical Features

- ▶ Integral safety stairway
 - Easy-to-inspect top manway
 - No guardrails to set up and take down
 - No moving parts or pins to break
 - Eliminates potential for guardrails violating height restrictions
- ▶ Easy-to-clean design reduces costs
 - V-shaped bottom for complete cleanout
 - Smooth wall interior
 - No corrugations
 - No internal rods
- ▶ 4 easily accessible, side-hinged manways
- ▶ Multiple 4-inch valved fill/drain ports in front and rear

- ▶ 3-inch fill line
- ▶ Vapor ready
- ▶ Lifting eyes
- ▶ Level gauges
- ▶ Fixed rear axle to fit in tight areas
- ▶ Nose rail cut-out for easy access when installing hose and fittings on the front/bottom of tank

Safety Features

- ▶ Safety stairway eliminates need for workers to get on top of the tank
- ▶ Grip strut steps to prevent slipping
- ▶ Rails and stair steps painted "safety yellow" for high visibility
- ▶ Safe Operation reminder decals applied
- ▶ Attached strapping charts
- ▶ Stringent and thorough maintenance program

Options

- ▶ Epoxy coated interior
- ▶ Bare steel interior
- ▶ Dual wall
- ▶ Heating coils

Comprehensive Service

Adler Tank Rentals provides containment solutions for many hazardous and non-hazardous products. We offer 24-hour emergency service, expert planning assistance, transportation services, tank/box repairs and tank/box cleaning. All of our rental equipment is serviced by experienced Adler technicians and tested to meet the most stringent industry standards.



Strategic Storage Solutions 800-421-7471 www.adlertankrentals.com

STORAGE TANKS | MOBILE LIQUID STORAGE | EMERGENCY LIQUID STORAGE | HAZARDOUS WASTE ENVIRONMENTAL TANKS | FRAC TANKS | ISO TANKS | INDUSTRIAL WASTE TANKS | INDUSTRIAL TANKS SOLUTIONS STORAGE TANKS | WASTE STORAGE TANKS | HAZARDOUS SOLUTION STORAGE TANKS OSHA TANKS | NESHAP TANKS | EMERGENCY RESPONSE TANKS | STORAGE TANKS | MOBILE LIQUID

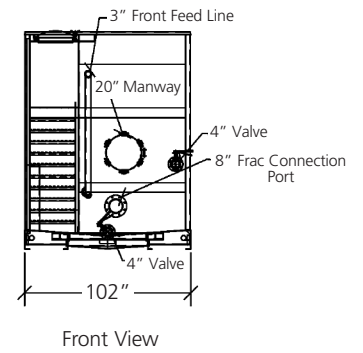
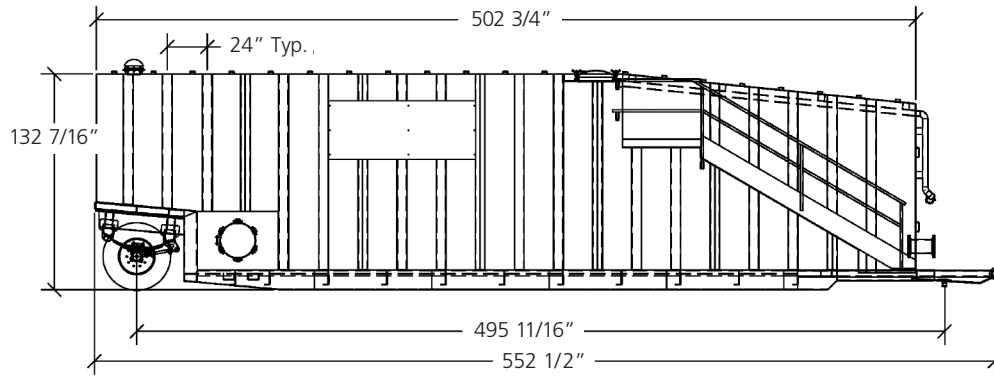
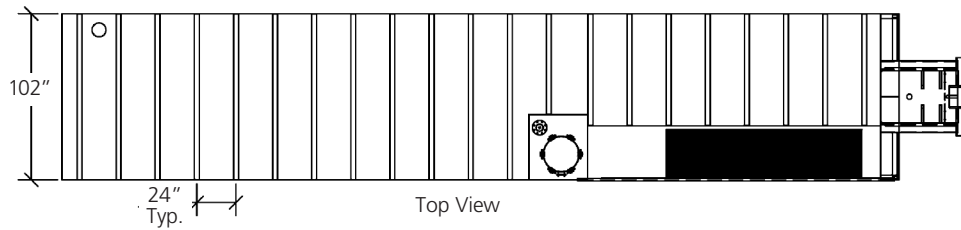

Application Description

Product to be Stored _____

Mixture of Chemicals _____

Rinse Water _____

pH _____

Non Hazardous

Hazardous (describe fully) _____

Temperature _____

Estimated Duration of Rental _____



Strategic Storage Solutions 800-421-7471 www.adlertankrentals.com

STORAGE TANKS | MOBILE LIQUID STORAGE | EMERGENCY LIQUID STORAGE | HAZARDOUS WASTE ENVIRONMENTAL TANKS | FRAC TANKS | ISO TANKS | INDUSTRIAL WASTE TANKS | INDUSTRIAL TANKS SOLUTIONS STORAGE TANKS | WASTE STORAGE TANKS | HAZARDOUS SOLUTION STORAGE TANKS OSHA TANKS | NESHAP TANKS | EMERGENCY RESPONSE TANKS | STORAGE TANKS | MOBILE LIQUID