SPILL CONTAINMENT BERMS



STURDY, FLEXIBLE AND RESISTANT TO A WIDE RANGE OF CHEMICALS, ADLER CONTAINMENT BERMS ARE A RELIABLE, PRACTICAL SOLUTION FOR SPILL PROTECTION. THESE VERSATILE SYSTEMS ARE USED IN A VARIETY OF APPLICATIONS, INCLUDING SPILL CONTAINMENT FOR BOXES AND CONTAINERS, DOT TANKS, FRAC TANKS, TRUCKS, DRUM STORAGE AND WASH PADS.

Adler containment berms are constructed from 40-mil polyethylene, making them durable and reusable. The systems are lightweight, easy to transport and simple to assemble. Berm walls are collapsible, allowing vehicles to drive through without damaging the berm itself.

Features

- ▶ Single-piece, non-woven, 40-mil polyethylene
- ▶ Puncture-resistant ground matting
- ▶ Ultraviolet and chemical resistant
- ▶ Lightweight, easy to transport
- ▶ Simple to assemble
- ▶ Reusable
- ▶ Collapsible walls allow vehicle drive-through
- ▶ Optional "Track Guard" may be used to protect against tire abrasions
- ▶ Multiple sizes available



Applications

- ▶ Frac tanks
- ▶ Mini fracs
- ▶ Roll-off containers
- ▶ Tanker trucks
- ▶ DOT tanks
- ▶ Wash pads
- ▶ Drum storage

Comprehensive Service

Adler Tank Rentals provides containment solutions for many hazardous and non-hazardous products. We offer 24-hour emergency service, expert planning assistance, transportation services, tank/box repairs and tank/box cleaning. All of our rental equipment is serviced by experienced Adler technicians and tested to meet the most stringent industry standards.



Strategic Storage Solutions 800-421-7471 www.adlertankrentals.com

STORAGE TANKS | MOBILE LIQUID STORAGE | EMERGENCY LIQUID STORAGE | HAZARDOUS WASTE ENVIRONMENTAL TANKS | FRAC TANKS | ISO TANKS | INDUSTRIAL WASTE TANKS | INDUSTRIAL TANKS SOLUTIONS STORAGE TANKS | WASTE STORAGE TANKS | HAZARDOUS SOLUTION STORAGE TANKS OSHA TANKS | NESHAP TANKS | EMERGENCY RESPONSE TANKS | STORAGE TANKS | MOBILE LIQUID

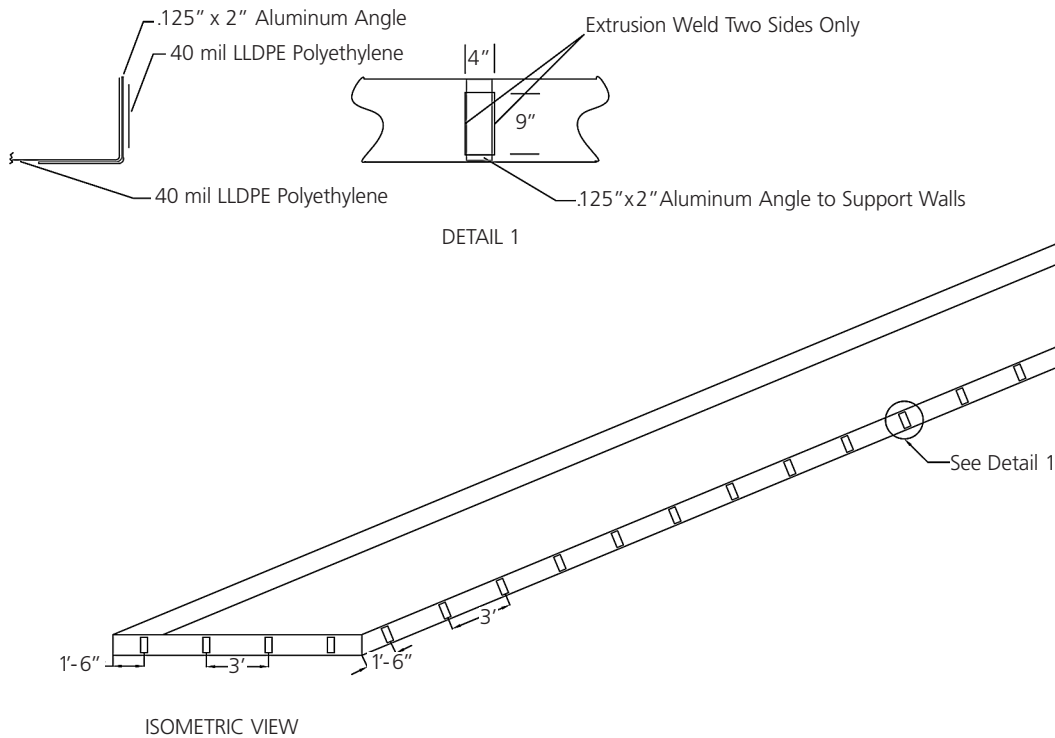

Application Description

Product to be Stored _____

Mixture of Chemicals _____

Rinse Water _____

pH _____

Non Hazardous

Hazardous (describe fully) _____

Temperature _____

Estimated Duration of Rental _____



Strategic Storage Solutions 800-421-7471 www.adlertankrentals.com

STORAGE TANKS | MOBILE LIQUID STORAGE | EMERGENCY LIQUID STORAGE | HAZARDOUS WASTE ENVIRONMENTAL TANKS | FRAC TANKS | ISO TANKS | INDUSTRIAL WASTE TANKS | INDUSTRIAL TANKS SOLUTIONS STORAGE TANKS | WASTE STORAGE TANKS | HAZARDOUS SOLUTION STORAGE TANKS OSHA TANKS | NESHAP TANKS | EMERGENCY RESPONSE TANKS | STORAGE TANKS | MOBILE LIQUID